

X-Tract

Collin Nortier

DES 231
Spring 2024
ID III

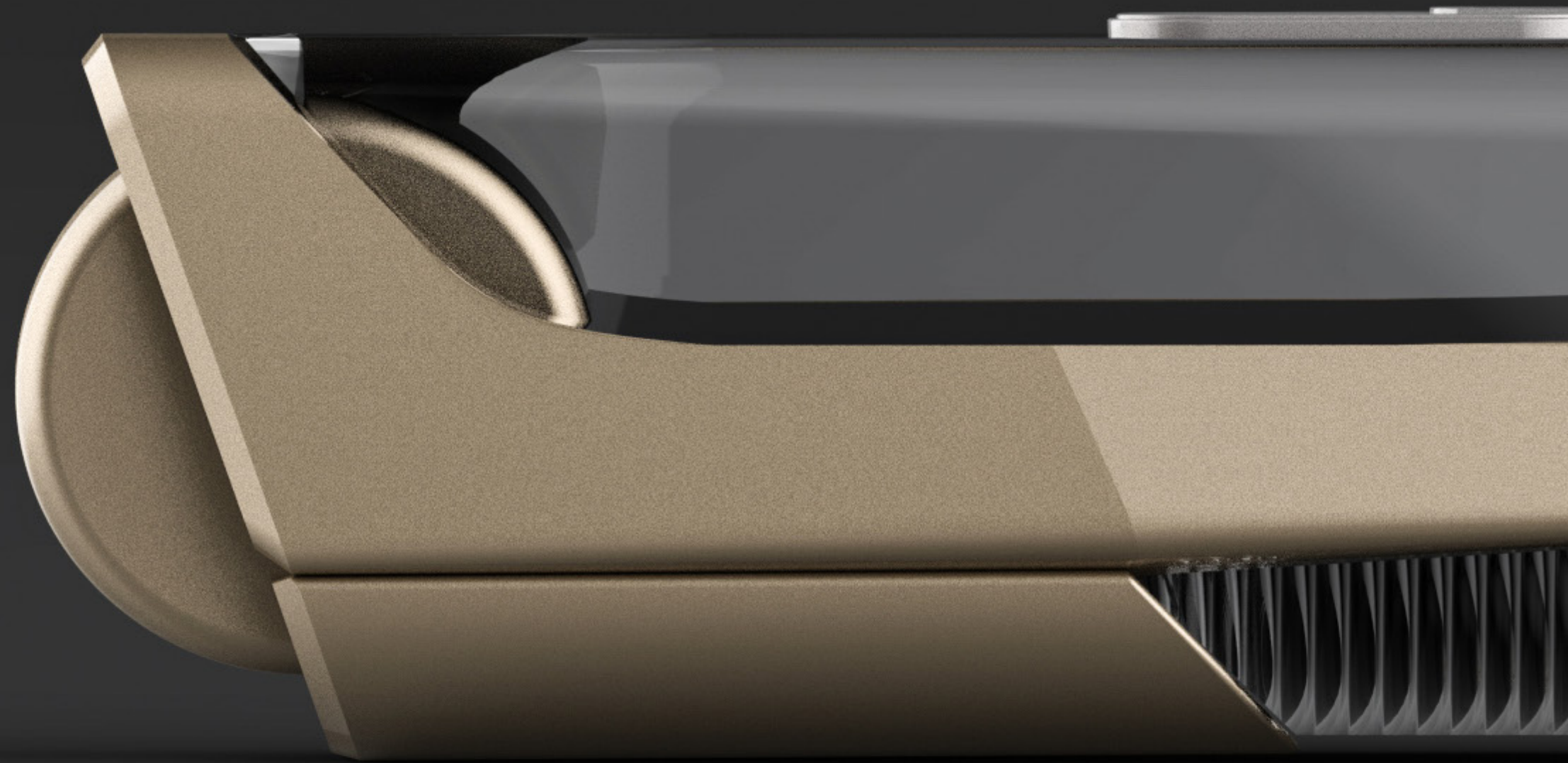

Everyday

Cleaning up spills in the car is such a daunting task, due to the fact that most methods takes an entire process to have a stain removed.

“53% of people surveyed have had a drink get spilled on the floor/upholstery”

- People.com



Problems

Modern spot-cleaners lack:

- Versatility
- Accessibility
- Speed

“You fill it up to the water line, and find yourself barely even using half of it. You have no choice but to dump the rest out. You find yourself wasting a lot of water.”

- Rick N.



Primary



Jennifer N, (Commuter)

When I spill liquids on my cloth seats, it becomes such a hassle to clean up the entirety of it. It's such a long process for such a small task.

EASE OF USE?



Phill B, (Retired)

I use my old vaccuum I used to keep in the house to vaccuum up dirt in the car. It's rather large, but gets the job done.

COMPACT?

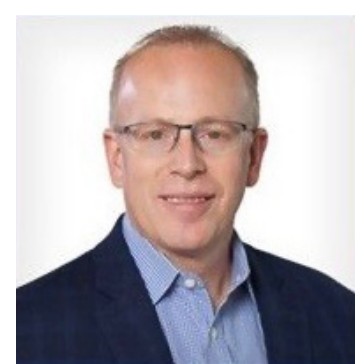

Tom G, (Auto Detailer)

I have to keep walking around the backside of the car to reach the opposite side. There needs to be an easier way to maneuver around the car when all the tools are plugged in.

BATTERY
POWERED?

Insights

Have to flip water tank completely upside down to put back on machine.

Bulky

Occasionally leaks water.

No sort of grip for the hand. Just a hard piece of plastic.

Hose doesn't reach very far.

Back pain from constant bent position.

How might we design an extractor that is specific towards cleaning spills in the car?

Criteria

Inspiration from sleek/modern look of current automobiles.

- Collapsibility
- Ease of Access
- Comfortable Grip
- Lightweight
- Sleek / Minimal



Ideation

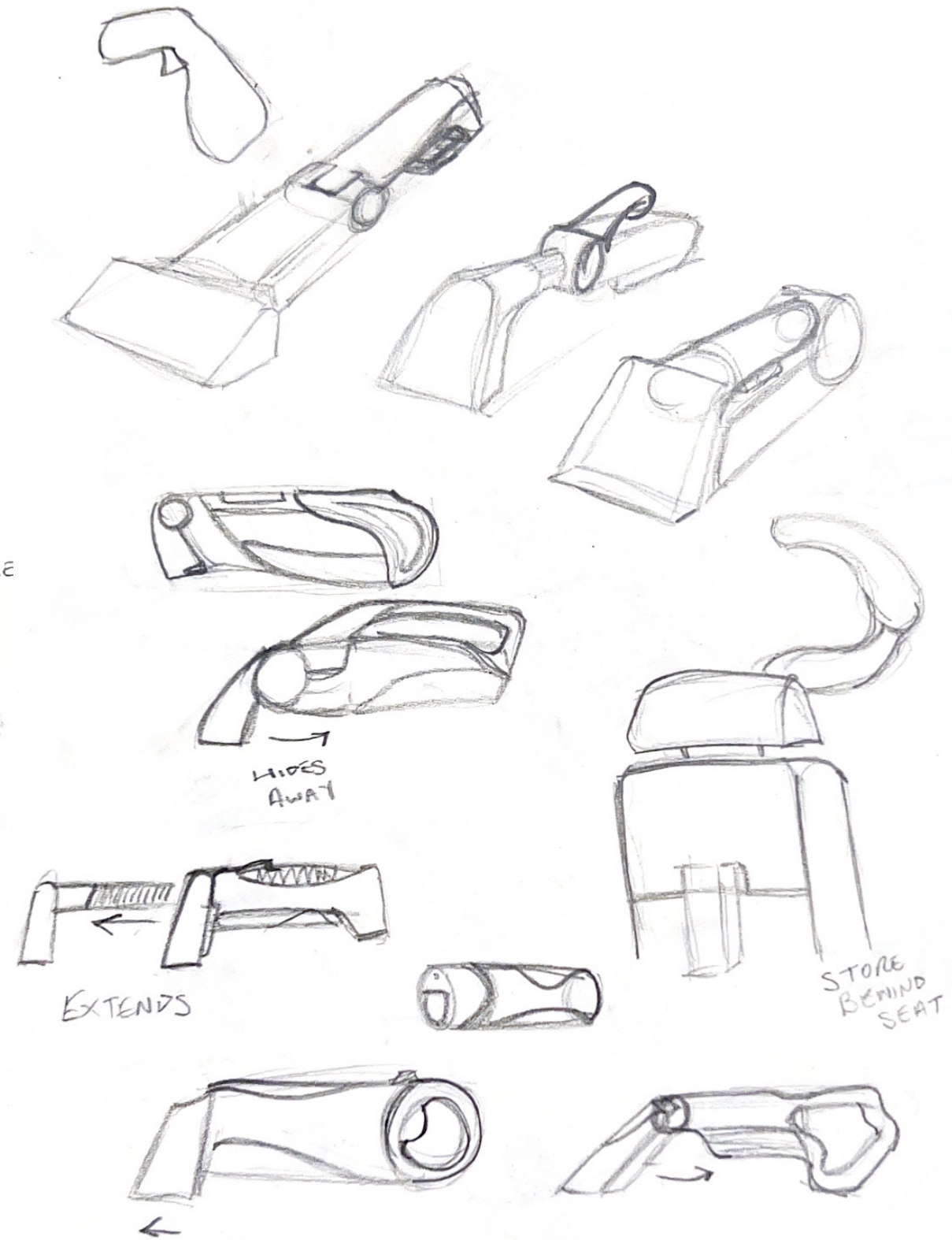
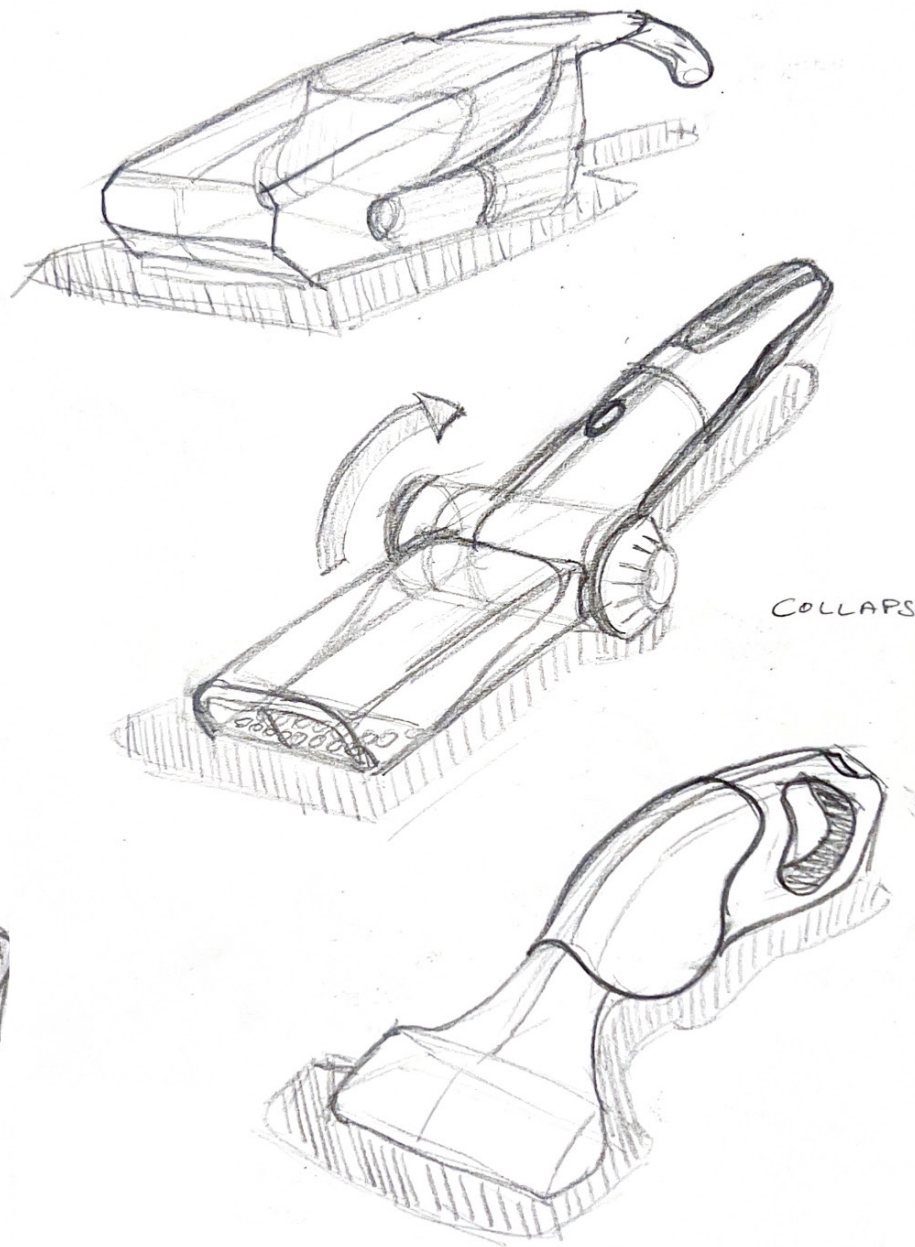
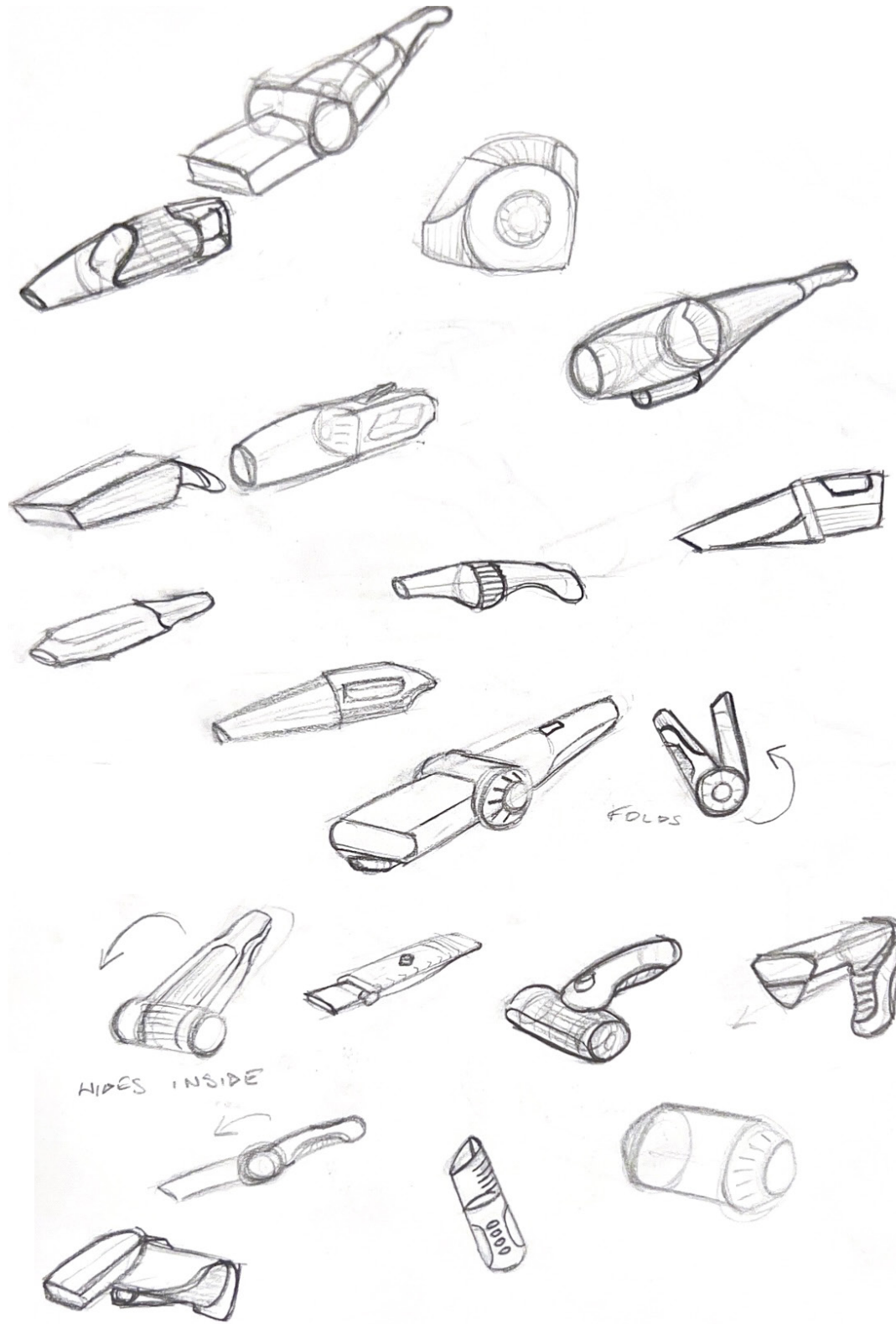

Progression

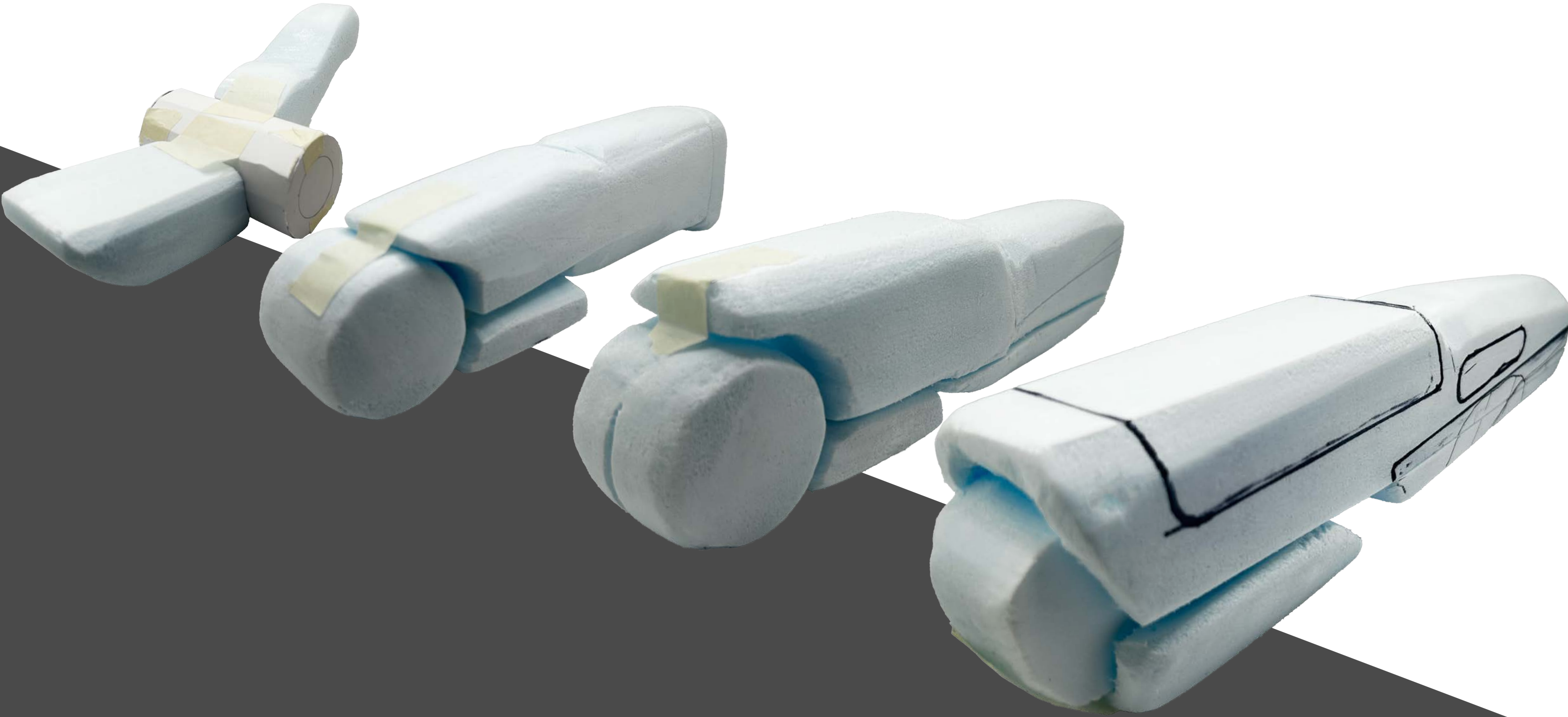

Follow Up

- Nozzle fits into cupholders
- Ergonomic grips style

DYSON FEEDBACK

- Balance
 - Internal functions
- Measure
 - How much liquid should it hold?
- Recharge
 - Cigarette lighter?
 - USB Port?



Market Matrix

TARGET



\$112

- Cheap
- User has to wrap cord around the body of the unit



\$122

- Small
- Heavy for one hand use
- Battery doesn't last long.



\$135

- Easy to store
- Poor suction
- Bulky



\$165

- Space for cord to live
- Noisy
- Cord gets tangled



\$1800

- Very powerful
- Extremely expensive

Refinement

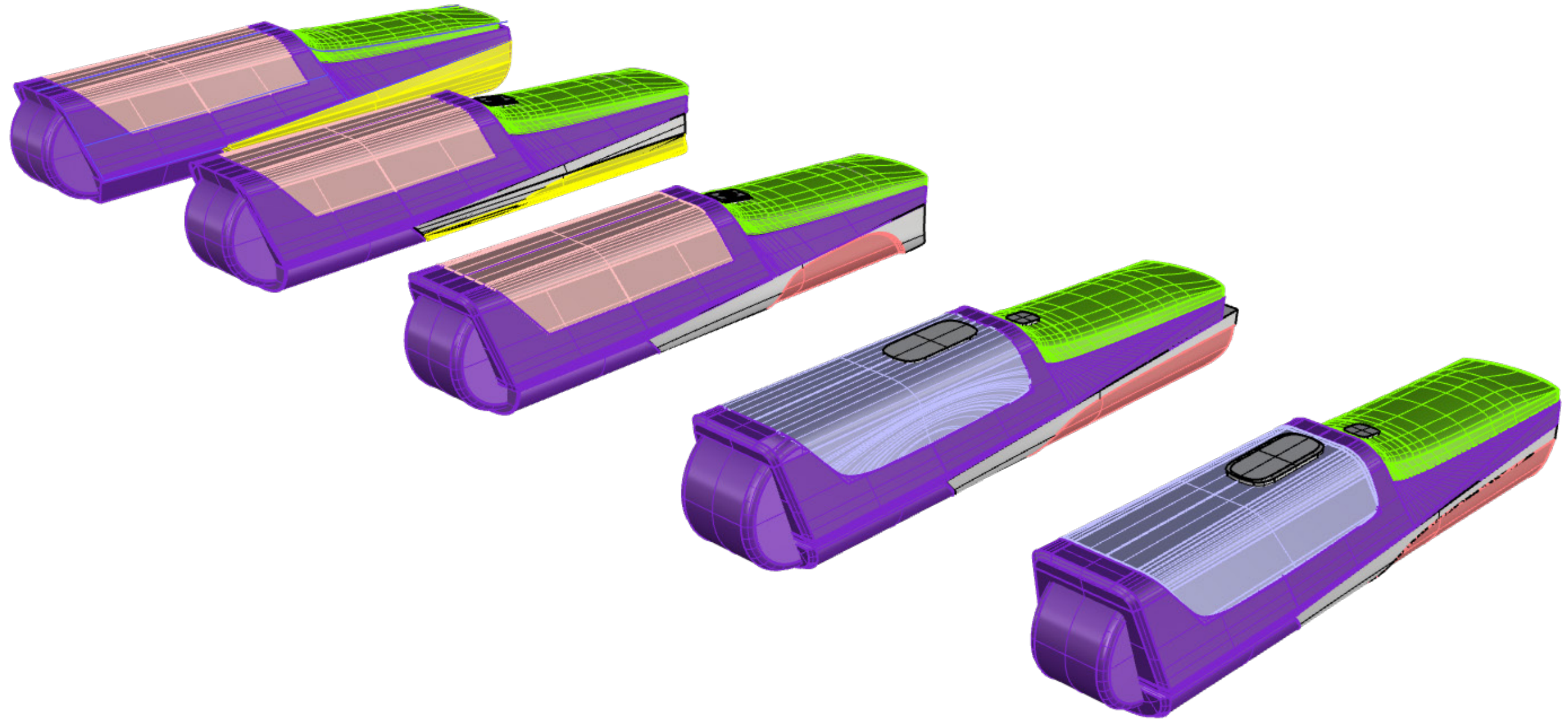

X-TRACT

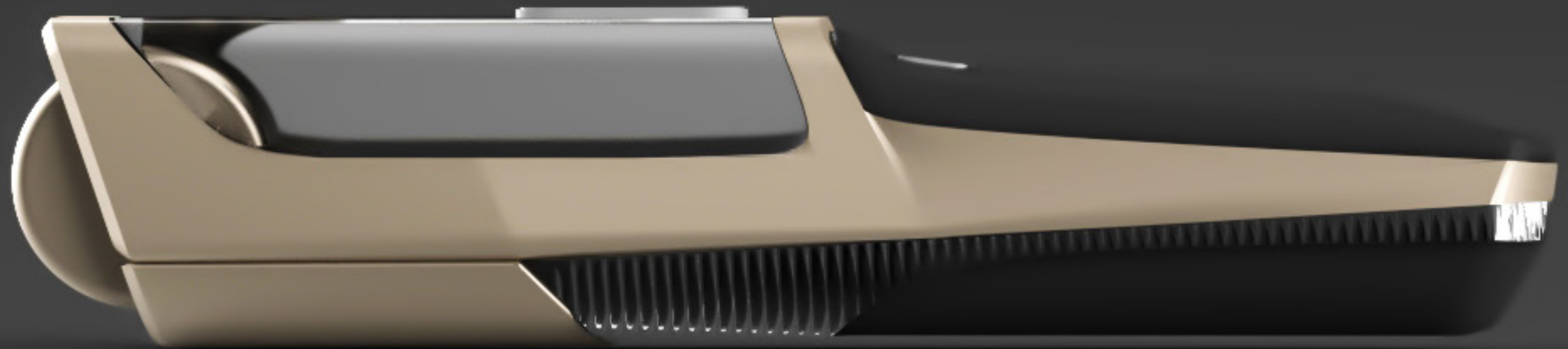

The all new X-Tract offers its user a streamlined design. With the combination of both sleek styling and hand-formed grips, the X-Tract simplifies the process of removing liquids from seats while on-the-go.

Features

Easily stored up front to tackle quick stains while on-the-go.

- Rechargeable battery via USB-C
- Lives in the car
- Collapsible
- Anti-Slip Rubber Grips
- 2 Removable Tanks
- Conforming Button

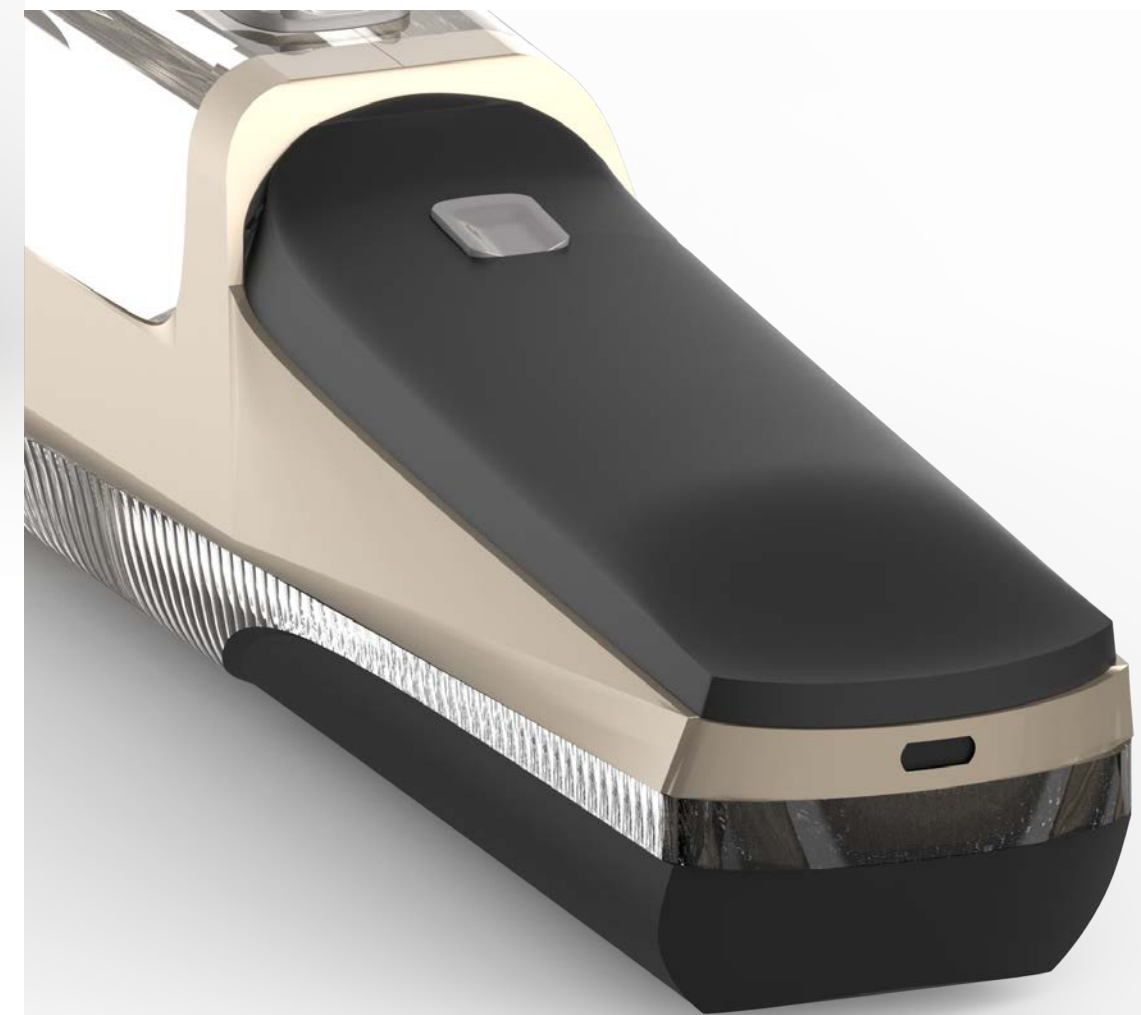

Exploded

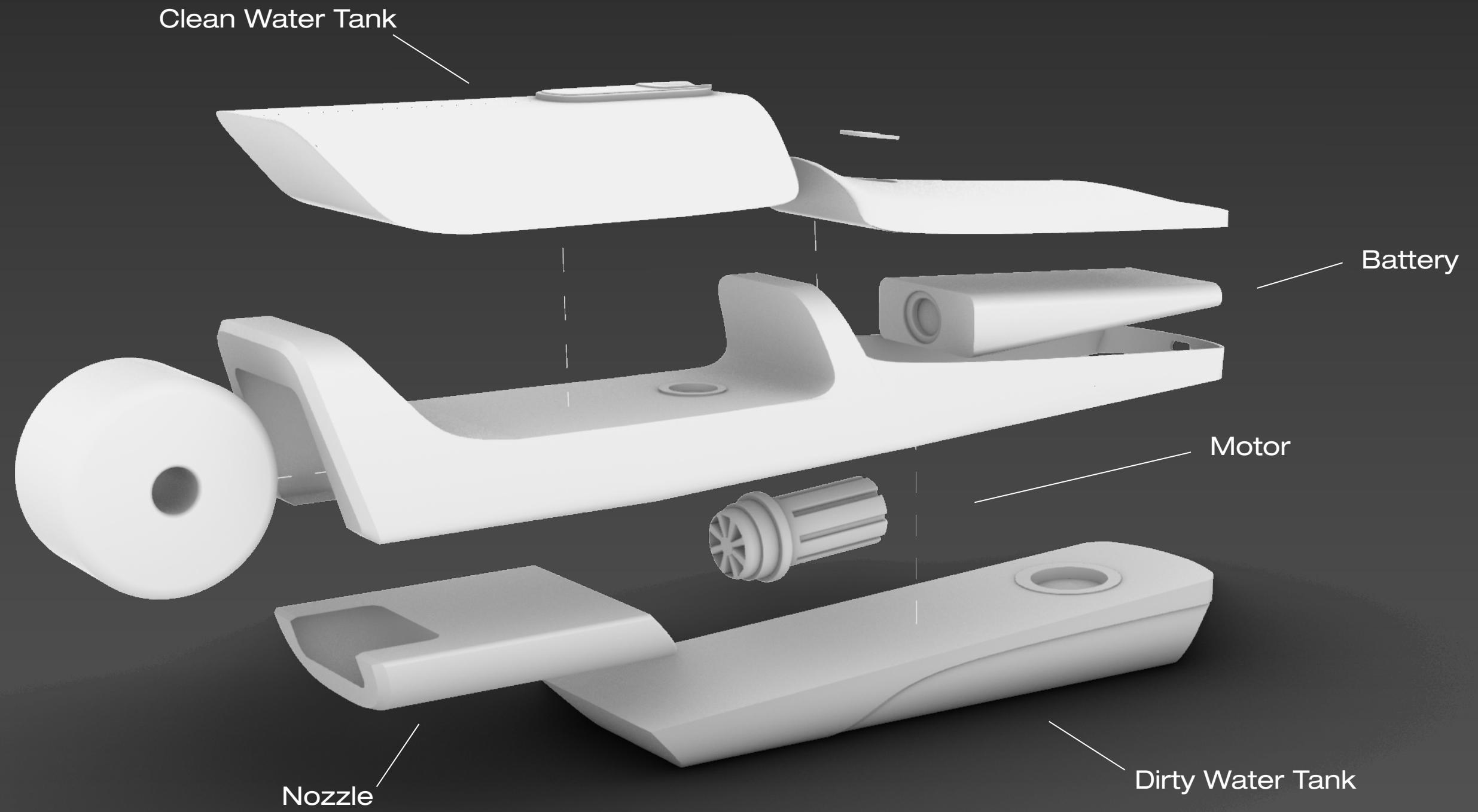

Process

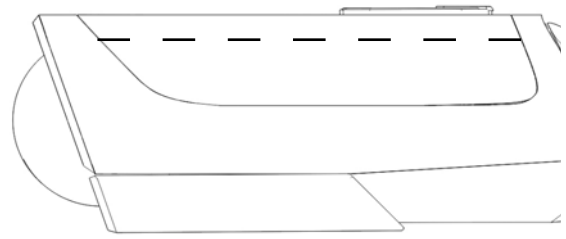

FILL with
water/solution

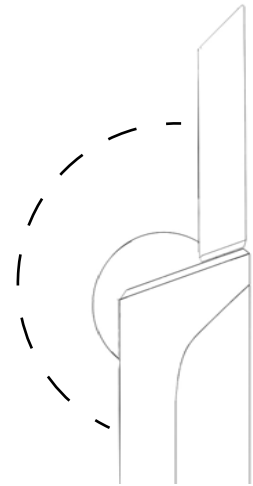

ROTATE
nozzle

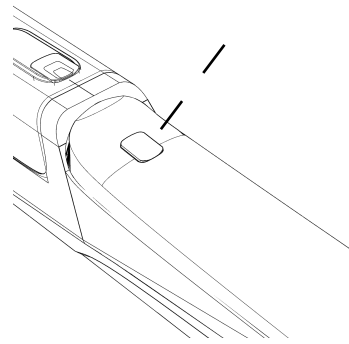

PRESS the
button to
turn on

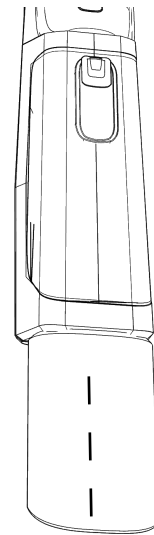

HOLD against
stain until dry

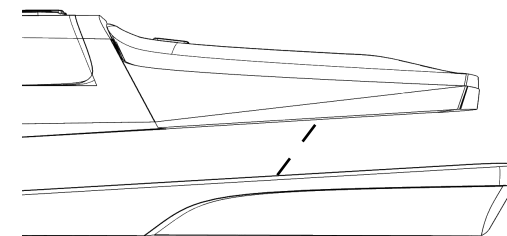

REMOVE dirty
water tank &
empty

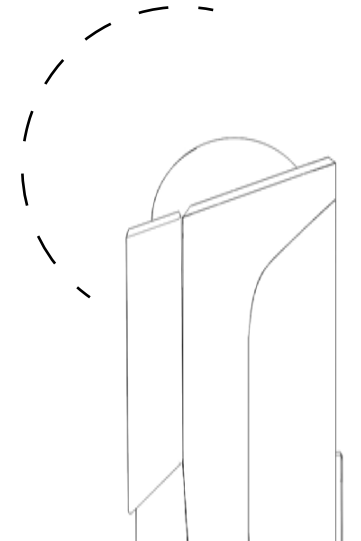

STORE back
into spot of
choice

Using the X-Tract is as
easy as it gets when
extracting a stain.

It can be broken down
into 6 SIMPLE STEPS.

SEE ABOVE

The all new X-Tract offers its user a collapsible feature which allows for placement near the driver of any vehicle.

WHERE TO STORE:

- Glove Compartment
- Under the Seat
- Underneath the Center Console
- Behind the Seat Pocket



CMF

The X-Tract is offered in 4 distinct colors that go along with any automobiles' interior.

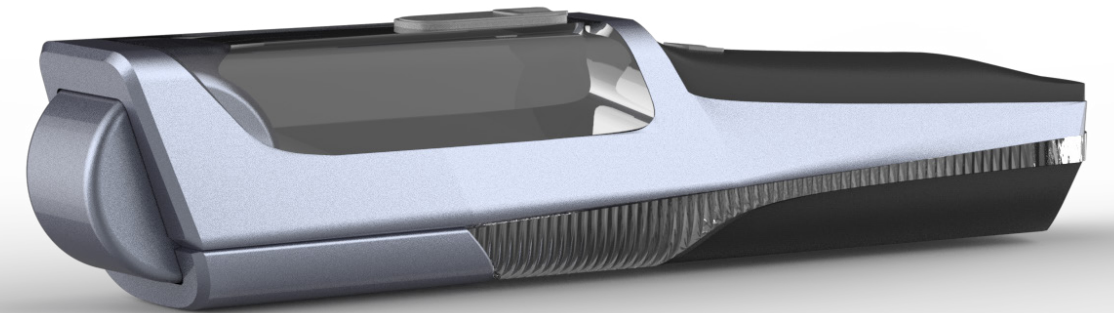
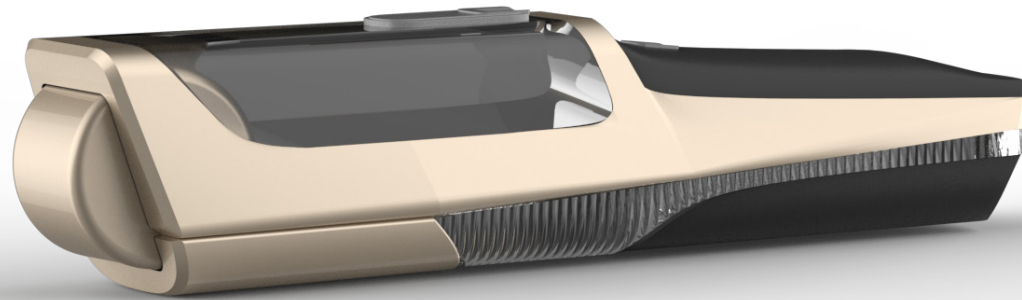

- CHAMPAGNE

- SLATE

- SILVER

- MIDNIGHT

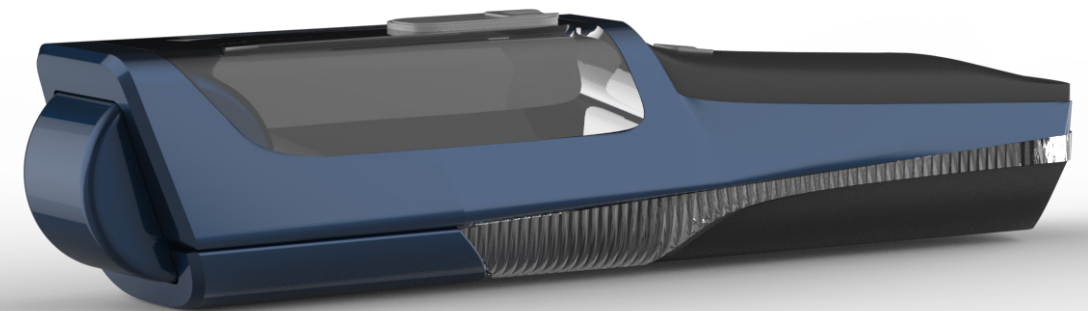
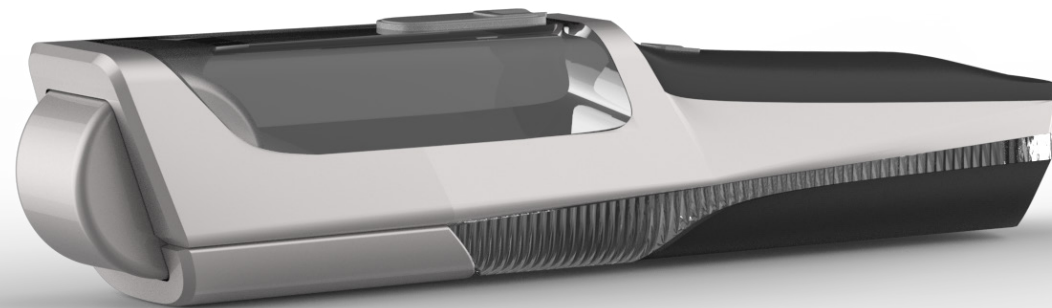

Thank You

